

Versteel

Thank you for your purchase. We hope you have many great years of use from the Mobile Privacy Screen and all our products. If you have any questions which are not covered by these instructions, please contact customer service at 800.827.2120 or customerservice@versteel.com

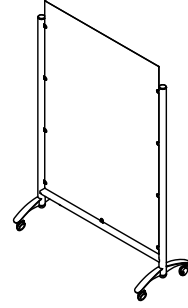

DOCUMENT CONTAINS 3 PAGES		ASSEMBLY INSTRUCTIONS: MOBILE PRIVACY SCREEN COMPONENT ASSEMBLY	
<p>COMPONENTS:</p> <ul style="list-style-type: none">1 LEFT UPRIGHT2 RIGHT UPRIGHT3 STRETCHER4 METAL OR ACRYLIC PANEL5 PANEL FASTENERS6 UPRIGHT SCREWS			<p>Notes: THE INCLUDED FASTENERS WILL DIFFER BASED ON THE PANEL MATERIAL</p>
<p>TOOLS REQUIRED:</p> <ul style="list-style-type: none">1 1/8" ALLEN WRENCH2 PHILIPS SCREWDRIVER3 3/8" WRENCH (METAL ONLY)4 FLAT SCREWDRIVER (ACRYLIC ONLY)			

VERSTEEL

270.INS.MPS
9/16/2020

2332 Cathy Lane
Jasper Indiana 47546
800 876 2120
Versteel.com

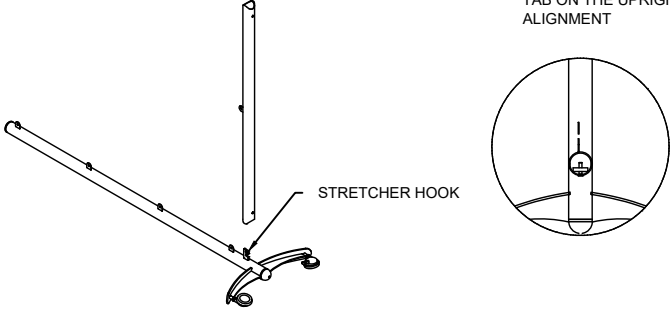
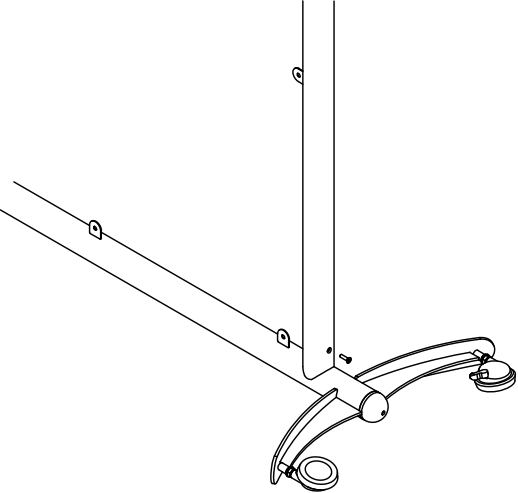
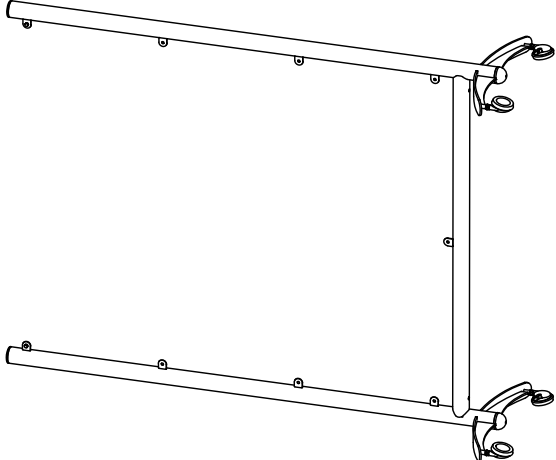
PAGE 2 OF 3	ASSEMBLY INSTRUCTIONS: MOBILE PRIVACY SCREEN COMPONENT ASSEMBLY
<p>STEP ONE</p> <p>LAY ONE OF THE UPRIGHTS ON THE GROUND WITH THE TABS FACING UPWARD.</p> <p>MAKING SURE THE TABS ARE ALIGNED, SLIDE THE STRETCHER OVER THE STRETCHER HOOK.</p>	<p>Notes: ENSURE THAT THE TABS ON THE STRETCHER AND THE TAB ON THE UPRIGHT ARE IN ALIGNMENT</p>  <p>Diagram illustrating Step One: A long horizontal stretcher with a hook at one end is being positioned over a vertical upright. A circular inset shows a close-up of the hook and the upright's tab aligning.</p>
<p>STEP TWO</p> <p>WHEN THE HOLE IN THE STRETCHER IS ALIGNED WITH THE THREADS IN THE STRETCHER HOOK, INSET ONE OF THE UPRIGHT SCREWS AND TIGHTEN WITH THE ALLEN WRENCH.</p>	 <p>Diagram illustrating Step Two: The stretcher is now attached to the upright. One of the upright's screws is being inserted into the hole in the stretcher's hook.</p>
<p>STEP THREE</p> <p>WITH THE HELP OF A SECOND PERSON, LIFT THE REMAINING UPRIGHT.</p> <p>GUIDE THE STRETCHER HOOK INTO THE END OF THE STRETCHER.</p> <p>WHEN THE STRETCHER HOOK IS IN PLACE, USE THE REMAINING UPRIGHT SCREW TO FIX THE UPRIGHT TO THE STRETCHER.</p>	 <p>Diagram illustrating Step Three: The final assembly is shown. Two long stretchers are attached to a central vertical upright. One stretcher is horizontal, and the other is angled downwards.</p>



ASSEMBLY INSTRUCTIONS: MOBILE PRIVACY SCREEN
COMPONENT ASSEMBLY

STEP FOUR

STAND THE FRAME UPRIGHT

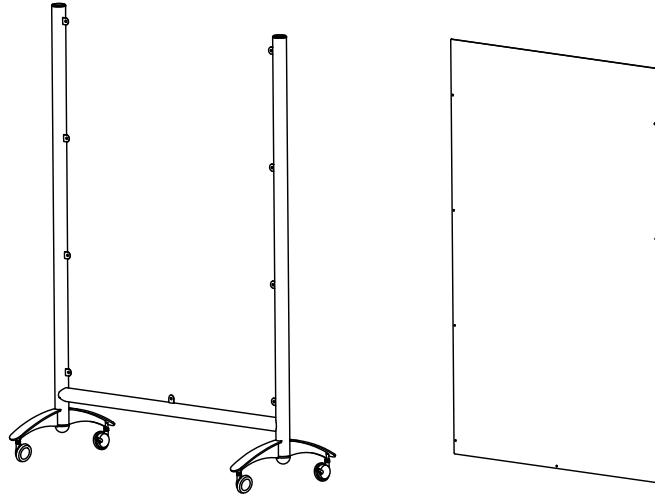

STEP FIVE

WITH THE HELP OF A SECOND PERSON, ALIGN THE HOLES IN THE PANEL WITH THE HOLES IN THE TABS OF THE FRAME.

WHEN THE TOPMOST HOLES ARE ALIGNED, INSERT A SCREW AND THREAD IT INTO EITHER THE ACORN NUT OR THE BARREL NUT.

DO NOT FULLY TIGHTEN THE TOP TWO FASTENERS.

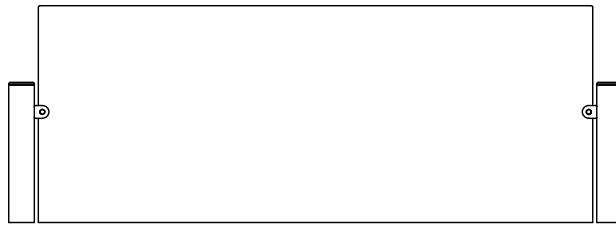

STEP SIX

WITH THE PANEL NOW HANGING FROM THE TOP TWO FASTENERS, INSTALL THE REMAINING FASTENERS.

DO NOT FULLY TIGHTEN ANY OF THEM UNTIL ALL OF THE FASTENERS ARE IN PLACE.

WHEN ALL FASTENERS ARE THREADED, TIGHTEN THEM DOWN.

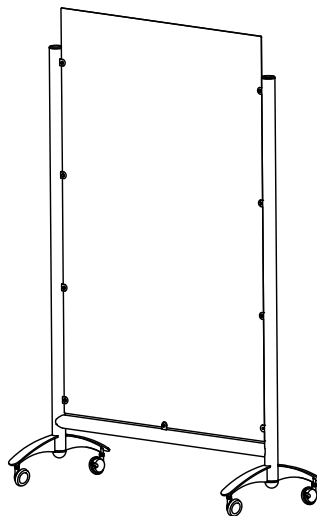

Notes:
DO NOT OVER TIGHTEN FASTENERS