

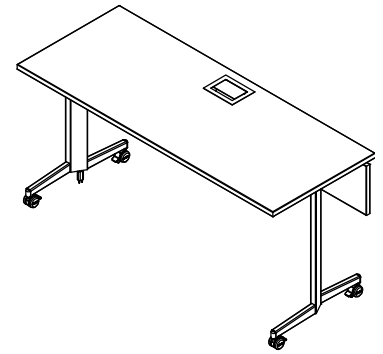

2332 Cathy Lane  
 Jasper, Indiana  
 47546  
 800.876.2120  
 812.482.9318 Fax  
 www.versteel.com

Thank you for your purchase. Versteel hopes that you have many great years of use from this table and from all our products. If you have questions that these instructions do not answer, please call customer service at 800.876.2120



**DOCUMENT CONTAINS 2 PAGES** **ASSEMBLY INSTRUCTIONS: ELIGA TRAINING**

<b>COMPONENTS:</b>		<b>QTY:</b>
1	7/8" BOARD SCREW	18
2	FIXED MODESTY (IF APPLICABLE)	1
3	MODESTY STUD ASSEMBLY (IF APPLICABLE)	2
4	CROSS DOWEL NUT (IF APPLICABLE)	2
5	TABLETOP	1
6	LEFT TABLE LEG	1
7	RIGHT TABLE LEG	1
8	ELECTRICAL UNIT (IF APPLICABLE)	1

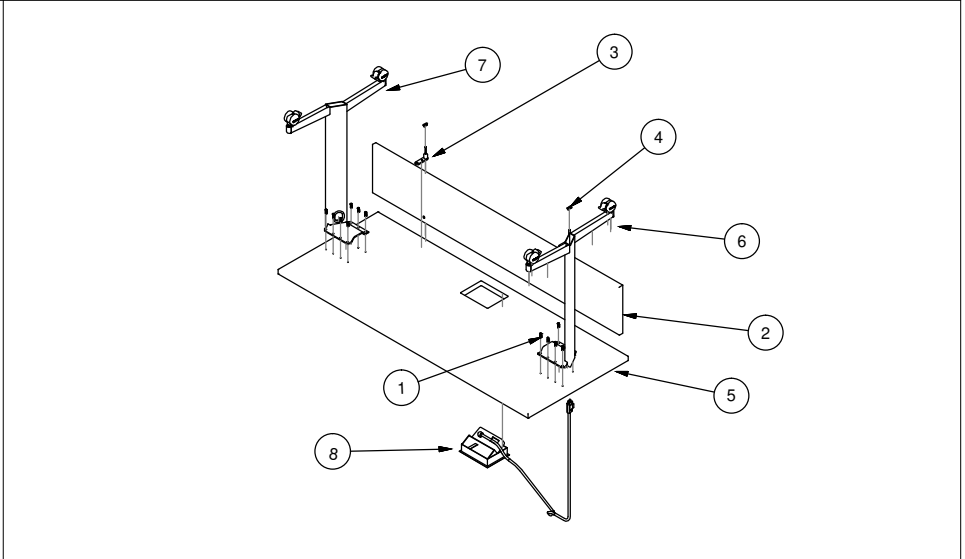

<b>TOOLS REQUIRED:</b>	
1	CORDLESS DRILL
2	FLATHEAD HEAD SCREWDRIVER

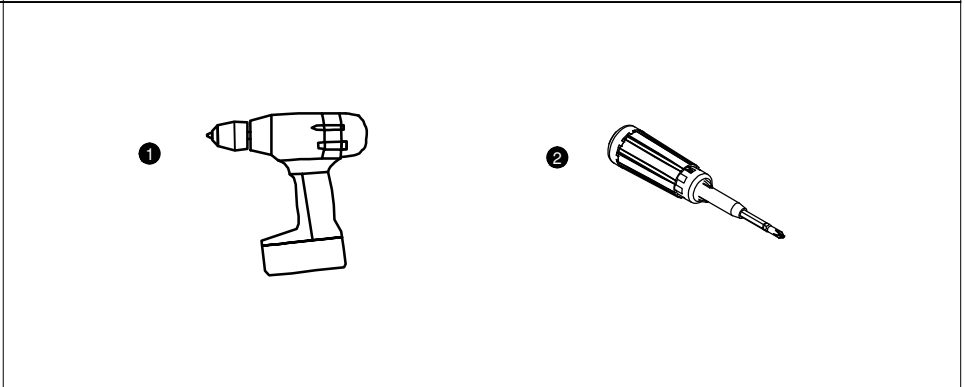

**STEP ONE (IF APPLICABLE)**

PLACE THE TABLETOP FACE DOWN. FEED THE CORD THROUGH THE CUTOUT, THEN INSERT THE ELECTRICAL UNIT FROM THE TOP SIDE. FEED THE CORD THROUGH CUTOUT IN TUBE AND DOWN INSIDE THE LEG UNTIL THE PLUG COMES OUT OF THE BOTTOM OF THE LEG. SCREW CLIPS ONTO TOP TO SECURE CORD.

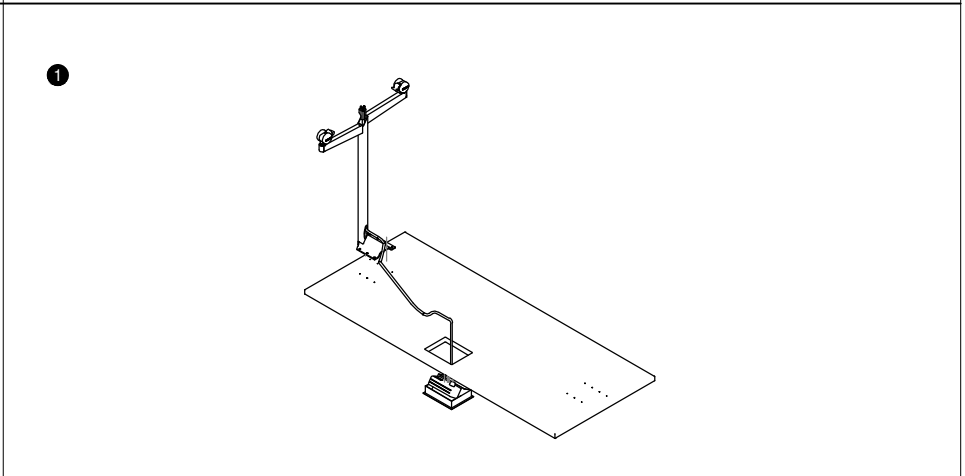



**STEP TWO**

PLACE BOTH LEGS IN THEIR RESPECTIVE POSITIONS AND LINE UP THE PRE-DRILLED HOLES WITH THE HOLES IN THE TOP PLATE. SCREW (14) 7/8" BOARD SCREWS INTO PLACE.

2

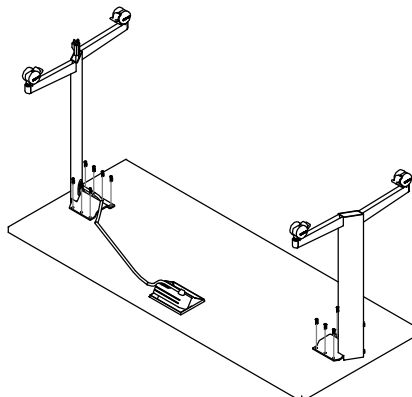

**STEP THREE (IF APPLICABLE)**

PLACE MODESTY PANEL ON END. PLACE (2) CROSS DOWEL NUTS INSIDE OF THE HOLES. SCREW (2) MODESTY STUD ASSEMBLIES INTO THEIR RESPECTIVE CROSS DOWEL NUTS.

3

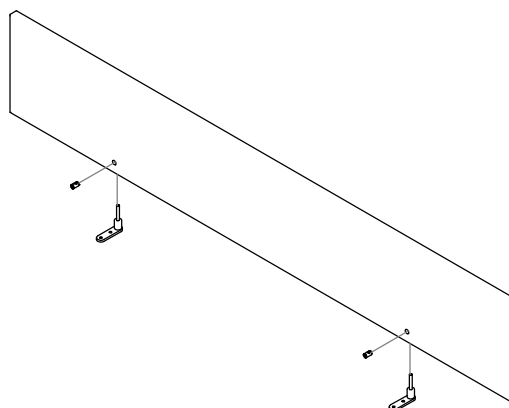

**STEP FOUR (IF APPLICABLE)**

PLACE ALL PARTS FROM STEP THREE ON THE TABLETOP. LINE UP THE HOLES FROM (2) MODESTY STUD ASSEMBLIES WITH THE HOLES ON THE TABLETOP. SCREW ON THE MODESTY USING (4) 7/8" BOARD SCREWS.

4

