

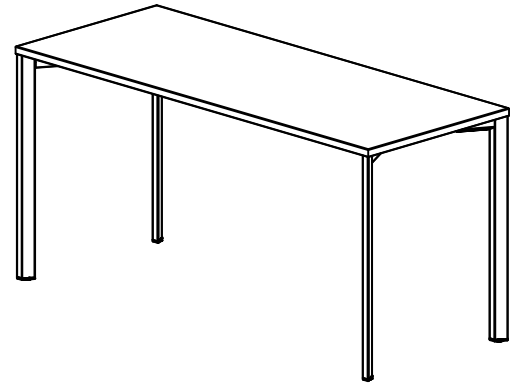

2332 Cathy Lane
 Jasper, IN
 47546
 800.876.2120
 812.482.9318 Fax
 www.versteel.com

Thank you for your purchase. Versteel hopes that you have many great years of use from this table and from all of our products. If you have questions that these instructions do not answer, please call customer service at 800.876.2120.



DOCUMENT CONTAINS 2 PAGES	ASSEMBLY INSTRUCTIONS: FIXED TABLE	
<p>COMPONENTS: QUANTITY:</p> <p>① TOP WITH ATTACHED SUPPORTS 1</p> <p>② ELIGA BASE A 1</p> <p>③ ELIGA BASE B 1</p> <p>○ MOUNTING HARDWARE SEE LIST</p>		
<p>TOOLS REQUIRED:</p> <p>① 5/32" HEX WRENCH OR DRIVER</p> <p>② CORDLESS SCREWDRIVER AND PH2 BIT</p>		
<p>COMPONENTS: QUANTITY:</p> <p>① #10 x3/4 FLAT HEAD WOOD SCREW 32</p> <p>② 5/16-18 x 1"FH SOCKET CAP SCREW 1</p>		
<p>ASSEMBLY: STEP ONE</p> <p>PLACE TOP FACE DOWN ON FLOOR OR OTHER STURDY WORK SURFACE AS SHOWN. ENSURE FACE SIDE IS PROTECTED FROM DAMAGE.</p> <p>PLACE LEGS ON BOTTOM SIDE OF TABLE AND INSERT TABS INTO SUPPORT ENDS.</p>		



ASSEMBLY: STEP TWO

ALIGN HOLES IN SUPPORT ENDS WITH CORRESPONDING HOLES IN TABS. INSERT AND TIGHTEN ALL 1/4-20 x 1/2" BHCS TO MOUNT BASES TO RAILS.

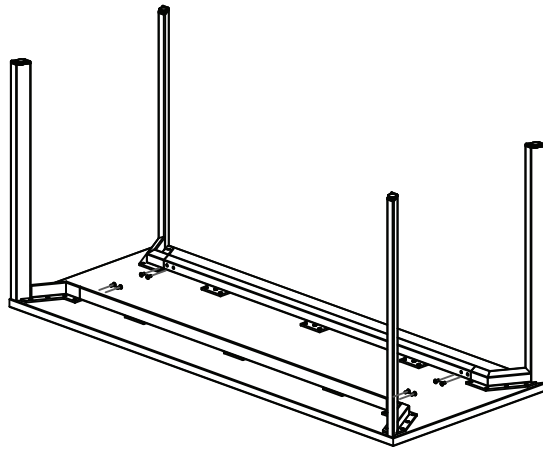

ASSEMBLY: STEP THREE

INSTALL FLAT HEAD WOOD SCREWS IN BASE PLATES USING DRIVER AND BIT. TAKE CAUTION NOT TO OVERTIGHTEN THE SCREWS IN THE TABLE. IT IS RECOMMENDED THAT THE DRIVER BEING USED BE SET AT A LOW TORQUE SETTING AND INCREASED UNTIL SCREWS WILL SIT FLUSH IN PLATE.

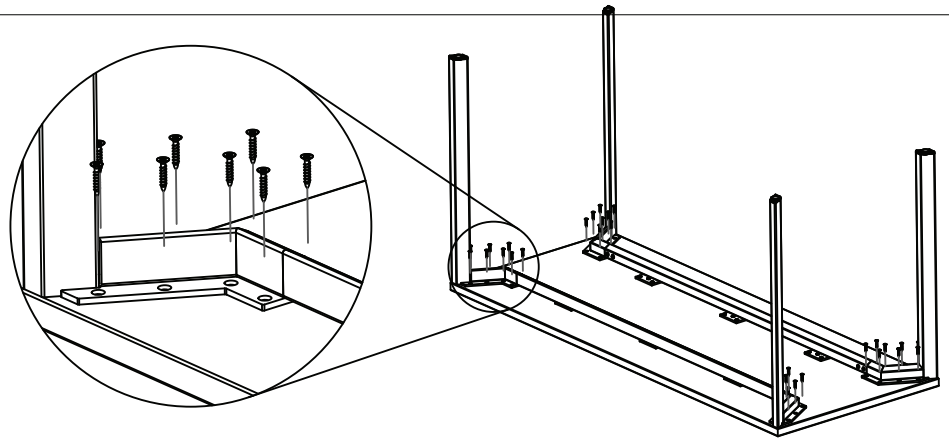

ASSEMBLY: STEP FOUR

FLIP TABLE INTO POSITION FOR USE

****USE CAUTION WHEN LIFTING TABLE****
*****MAY REQUIRE TWO-PERSON LIFT*****

