

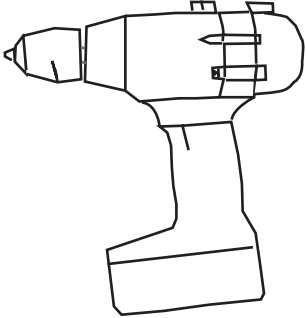

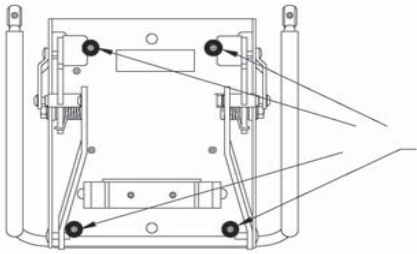

2332 Cathy Lane
 Jasper, Indiana
 47546
 800.876.2120
 812.482.9318 Fax
 www.versteel.com

Thank you for your purchase. Versteel® hopes that you have many great years of use from this table and from all of our products. If you have questions that these instructions don't answer, please call customer service at 800.876.2120.

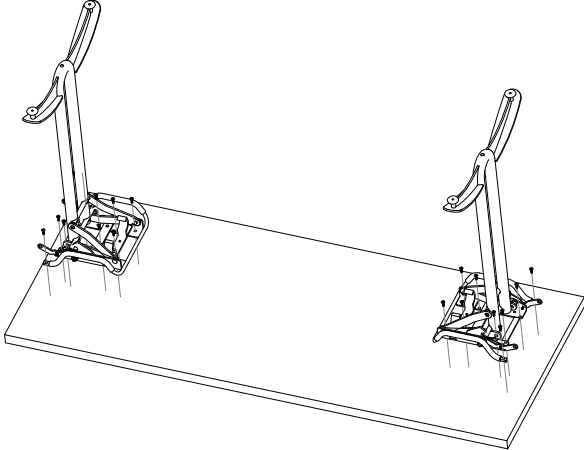

 DOCUMENT CONTAINS 1 PAGE	ASSEMBLY INSTRUCTIONS : VELA FOLDING TABLE LEGS
<p>COMPONENTS:</p> <ul style="list-style-type: none"> A TABLE TOP (1 QTY) B LEG/FOLDING PAN ASSEMBLY (2 QTY) C SCREWS (20 QTY) 	<p>TOOLS REQUIRED:</p> <p>POWER DRILL/DRIVER WITH ADJUSTABLE TORQUE</p> 
<p>ASSEMBLY : STEP 1 PLACE THE TOP FACE DOWN ON THE FLOOR. (MAKE SURE THE FLOOR IS CLEAN AND FREE OF ANY DEBRIS.)</p> <p>ASSEMBLY : STEP 2 LOCATE THE BASE PRE-DRILLS ON THE TOP. TYPICALLY THE HOLES FOR THE FOUR (4) CORNERS OF EACH FOLDING PAN WILL HAVE PRE-DRILLS ON THE TOPS. (DIAGRAM 1)</p> <p>PLACE LEG ASSEMBLIES OVER THE PRE-DRILLS. VERIFY THE CORRECT BASE ORIENTATION. (DIAGRAM 2)</p>	<p>1</p>  <p>(4) OUTER HOLES OF TOP PLATE ARE PRE-DRILLED IN TOP FOR LOCATING</p>
<p>NOTE: WHEN INSTALLING BASES, IT IS ABSOLUTELY CRITICAL THAT THE TORQUE SETTING ON THE POWER DRIVER BE AT THE LOWEST LEVEL NECESSARY TO SET THE SCREWS IN ALL THE WAY. OVERTORQUEING SCREWS WILL RESULT IN "STRIPPED-OUT" SCREWS, AND BASES MAY PULL AWAY FROM TOP WHILE IN USE. THIS IS ESPECIALLY COMMON WHEN HIGH-VOLTAGE POWER DRIVERS ARE USED WITH CLUTCH SETTING ON "DRILL/DRIVER."</p> <p>IT IS THE RESPONSIBILITY OF INSTALLER TO ENSURE THAT PROPER TORQUE SETTINGS ARE USED TO PREVENT STRIPPED-OUT SCREWS.</p>	<p>2</p>  <p style="text-align: right;">CONT'D </p>

ASSEMBLY : STEP 3

USING THE SCREWS PROVIDED, ATTACH EACH BASE TO THE TOP, ONE AT A TIME. THERE ARE A TOTAL OF TEN (10) SCREWS PER FOLDING PAN: FOUR (4) SCREWS WITH PRE-DRILLED HOLES AND SIX (6) ADDITIONAL WITHOUT PRE-DRILLED HOLES. (DIAGRAM 2)

REPEAT WITH OTHER BASE. (DIAGRAM 3)

3

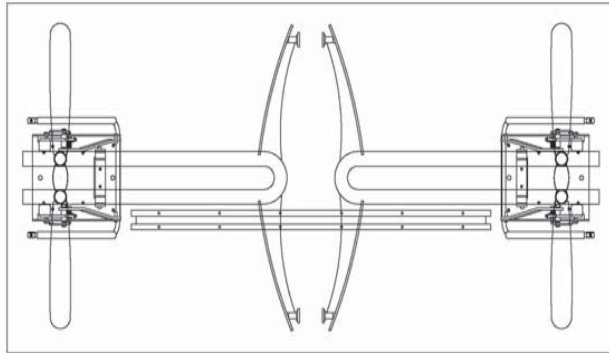

Regular

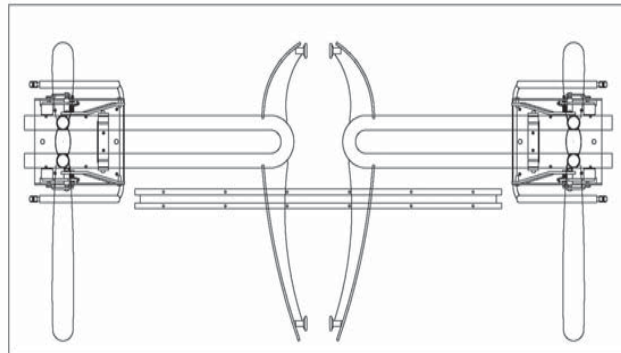

Cantilevered

ASSEMBLY : STEP 4

TEST FOLDING MECHANISM TO ENSURE PROPER OPERATION.

ASSEMBLY : STEP 5

TURN TABLE UPRIGHT. ADJUST GLIDES TO LEVEL THE SURFACE. (DIAGRAM 4)

4

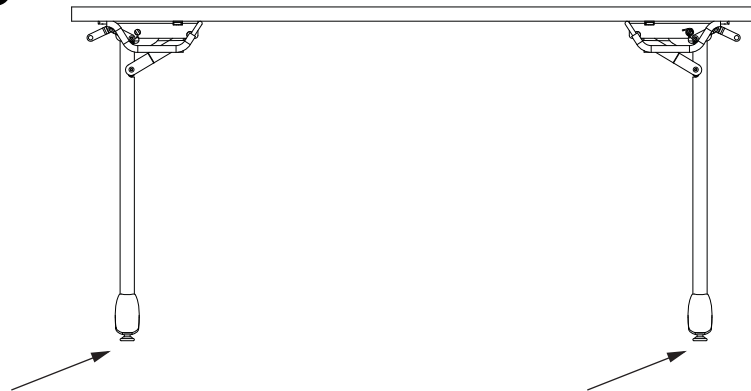

ENJOY YOUR NEW VERSTEEL TABLE!