

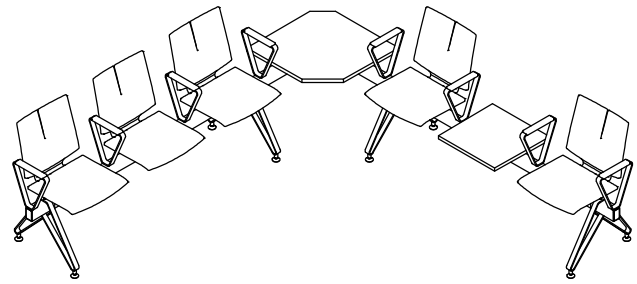

2332 Cathy Lane
 Jasper, Indiana 47546
 800.876.2120
 812.482.9318 Fax
 www.versteel.com

Thank you for your purchase. Versteel hopes that you have many great years of use from this seating unit and from all of our products. If you have questions that these instructions do not answer, please call customer service at 800.876.2120.



DOCUMENT CONTAINS: 2 PAGES	ASSEMBLY INSTRUCTIONS: QUANTA MAX BEAM													
<p>COMPONENTS:</p> <table border="0"> <thead> <tr> <th></th> <th style="text-align: center;">QUANTITY:</th> </tr> </thead> <tbody> <tr> <td>1 BEAM ASSEMBLY</td> <td style="text-align: center;">1</td> </tr> <tr> <td>2 SEAT SHELL</td> <td style="text-align: center;">VARIES</td> </tr> <tr> <td>3 ARM ASSY (IF APPLICABLE)</td> <td style="text-align: center;">VARIES</td> </tr> <tr> <td>4 TABLE (IF APPLICABLE)</td> <td style="text-align: center;">VARIES</td> </tr> <tr> <td>5 CORNER TABLE (IF APPLICABLE)</td> <td style="text-align: center;">VARIES</td> </tr> </tbody> </table>		QUANTITY:	1 BEAM ASSEMBLY	1	2 SEAT SHELL	VARIES	3 ARM ASSY (IF APPLICABLE)	VARIES	4 TABLE (IF APPLICABLE)	VARIES	5 CORNER TABLE (IF APPLICABLE)	VARIES		
	QUANTITY:													
1 BEAM ASSEMBLY	1													
2 SEAT SHELL	VARIES													
3 ARM ASSY (IF APPLICABLE)	VARIES													
4 TABLE (IF APPLICABLE)	VARIES													
5 CORNER TABLE (IF APPLICABLE)	VARIES													
<p>TOOLS REQUIRED:</p> <table border="0"> <tbody> <tr> <td>1 ALLEN WRENCH</td> <td></td> <td></td> </tr> <tr> <td>2 CORDLESS SCREWDRIVER</td> <td></td> <td></td> </tr> <tr> <td>3 BOLTS AND SCREWS (SUPPLIED BY VERSTEEL)</td> <td></td> <td> <ul style="list-style-type: none"> - #10 X 3/4" FLAT HEAD SCREWS (10 PCS PER BEAM TABLE, 16PCS PER CENTER TABLE) - M6X1 X 12MM BHCS (4 PCS PER SEAT) - 1/4-20" X 5/8" FHCS (8 PCS PER CORNER TABLE) - 1/4-20" X 2-1/2" BHCS (2 PCS PER ARM) </td> </tr> </tbody> </table>	1 ALLEN WRENCH			2 CORDLESS SCREWDRIVER			3 BOLTS AND SCREWS (SUPPLIED BY VERSTEEL)		<ul style="list-style-type: none"> - #10 X 3/4" FLAT HEAD SCREWS (10 PCS PER BEAM TABLE, 16PCS PER CENTER TABLE) - M6X1 X 12MM BHCS (4 PCS PER SEAT) - 1/4-20" X 5/8" FHCS (8 PCS PER CORNER TABLE) - 1/4-20" X 2-1/2" BHCS (2 PCS PER ARM) 					
1 ALLEN WRENCH														
2 CORDLESS SCREWDRIVER														
3 BOLTS AND SCREWS (SUPPLIED BY VERSTEEL)		<ul style="list-style-type: none"> - #10 X 3/4" FLAT HEAD SCREWS (10 PCS PER BEAM TABLE, 16PCS PER CENTER TABLE) - M6X1 X 12MM BHCS (4 PCS PER SEAT) - 1/4-20" X 5/8" FHCS (8 PCS PER CORNER TABLE) - 1/4-20" X 2-1/2" BHCS (2 PCS PER ARM) 												
<p>STEP ONE</p> <p>PLACE BEAM ASSEMBLY ON FLAT SURFACE. ALIGN THREADED INSERTS IN SEAT WITH HOLES IN BRACKETS, ATTACH ALL SEAT LOCATIONS TO BRACKETS USING M6 X 1 X 12MM BHCS AND ALLEN WRENCH, (4) SCREWS PER SEAT.</p>														

**STEP TWO (IF APPLICABLE)**

ALIGN PRE-DRILLED HOLES IN TOP WITH HOLES IN BEAM BRACKETS, ATTACH ALL TABLE LOCATIONS USING #10 X 3/4" FLAT HEAD SCREWS AND CORDLESS SCREWDRIVER, (10) PER TABLE.

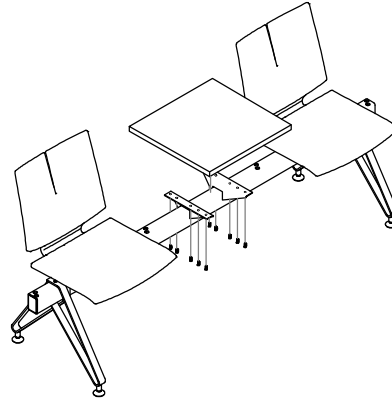
**STEP THREE (IF APPLICABLE)**

PLACE STANDOFFS ON ARM ASSEMBLY INTO HOLES IN BEAM, ATTACH ALL APPLICABLE ARM LOCATIONS USING 1/4"-20 X 2-1/2" BHCS AND ALLEN WRENCH, (2) PER ARM.

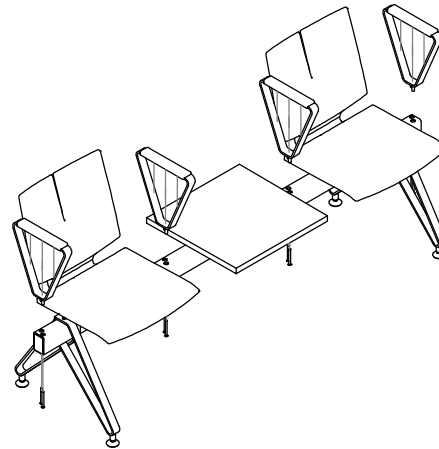
**STEP FOUR (IF APPLICABLE)**

ALIGN CORNER BEAM UNITS UTILIZING MITERED CORNERS TO ROUGHLY LOCATE. SLIDE CORNER TABLE BRACKETS OVER BEAM AND ALIGN HOLES IN BRACKETS WITH HOLES IN BEAM. SOME ADJUSTMENT OF BEAM LOCATION OR BRACKETS MAY BE REQUIRED. ATTACH CORNER TABLE USING 1/4"-20 X 5/8" FLAT HEAD SCREWS AND ALLEN WRENCH, (8) PER CORNER UNIT.

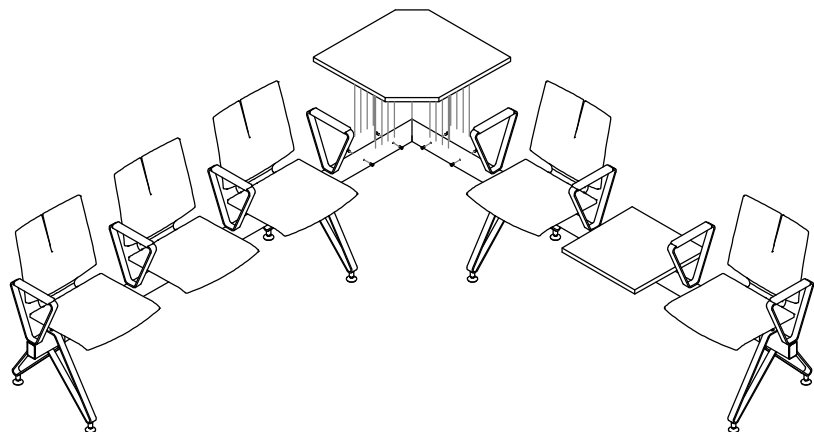

QUANTA MAX BEAM UNIT IS READY FOR USE