

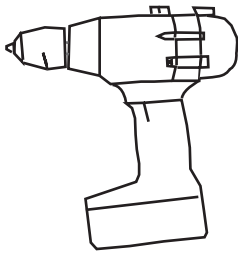

2332 Cathy Lane
 Jasper, Indiana
 47546
 800.876.2120
 812.482.9318 Fax
 www.versteel.com

Thank you for your purchase. Versteel® hopes that you have many great years of use from this item and from all of our products. If you have questions that these instructions don't answer, please call customer service at 800.876.2120.



<p> DOCUMENT CONTAINS 1 PAGE</p>	<p>ASSEMBLY INSTRUCTIONS HEIGHT ADJUSTMENT LOCK KIT - BHL</p>
<p>COMPONENTS:</p> <ul style="list-style-type: none"> A TIM TABLE (1 QTY) B SELF-TAPPING SCREWS (4 QTY) 6-32 x 5/16 PH PAN HD SELF TAPPING C STOP BUSHINGS (4 QTY) NYLON WASHER, 3/8 x .194 x 1/8 	<p>TOOLS REQUIRED:</p> <p>POWER DRILL/DRIVER WITH PHILLIPS BIT</p> 
<p>ASSEMBLY : STEP 1 POSITION TABLE TO THE DESIRED HEIGHT AS INSTRUCTED ON THE TABLE OPERATION LABEL, LOCATED ON THE UNDERSIDE OF THE TOP.</p> <p>ASSEMBLY : STEP 2 LOCATE THE PREDRILL HOLE IN THE LOWER LEG ASSEMBLY. THIS CAN BE FOUND IN THE ROUND HEIGHT POSITIONER HOLE DIRECTLY ABOVE OR BELOW THE PUSH PIN HEIGHT ADJUSTER.</p> <p>ASSEMBLY : STEP 3 PLACE STOP BUSHING INTO THE UPPER LEG HOLE AND INSTALL THE SELF-TAPPING SCREW INTO THE HOLE TO SECURE THE BUSHING. (DIAGRAM 1)</p> <p>THE SCREW AND STOP CAN EASILY BE REMOVED TO ALLOW RESETTING THE TABLE HEIGHT AS NEEDED.</p>	<p>1</p> 